

Installation Instructions

Tools Required:
7/16" Wrench or socket

1. Set Anti-Tipper Wheel Height

Temporarily place an anti-tipper bracket in the proper mounting position (Diagram A). Select height adjustment for wheel bracket that is closest to **but not contacting** floor. Remove anti-tipper bracket and install left and right wheel brackets using the 1 1/4" Carriage bolts, flat washers and lock nuts provided.

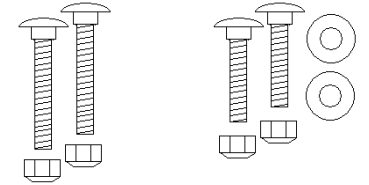
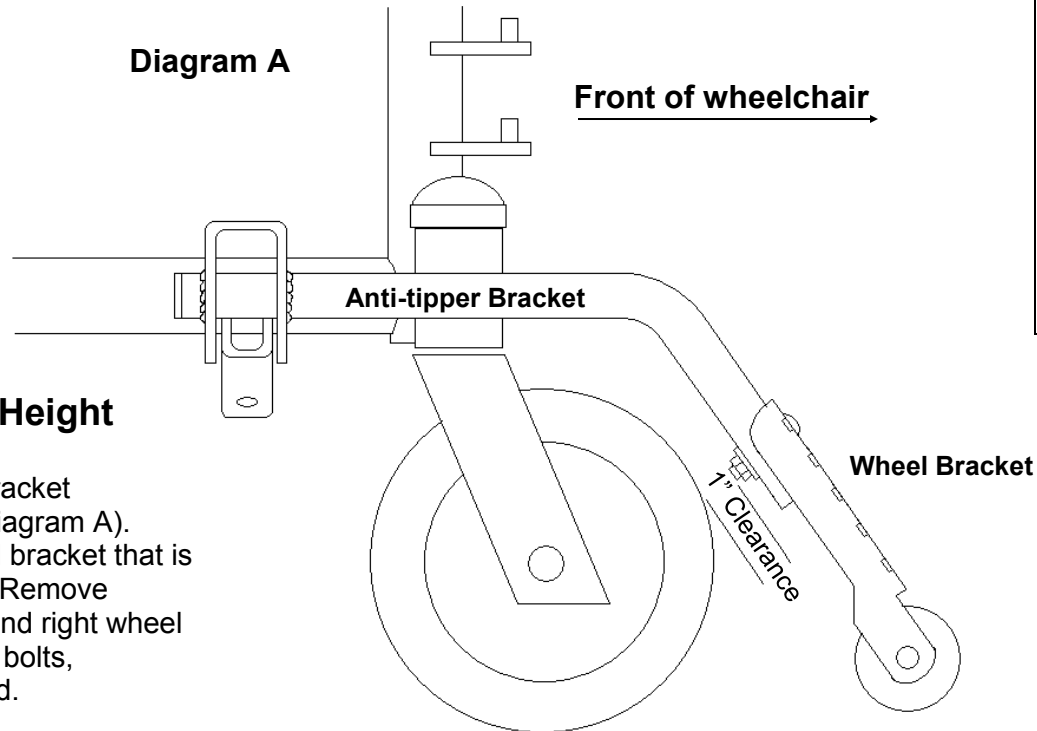

2 1/4" Carriage Bolts
Use for
Anti-tipper Brackets.

1 1/4" Carriage Bolts
Use for
Wheel Brackets.

2. Install Anti-Tipper Brackets

Anti-tippers must be installed on outer side of chair frame and front wheel posts as shown.

Place mounting bracket over horizontal frame tube as illustrated in Diagram B. Position front caster in the most forward position (Diagram A) and make sure there is approximately 1" of clearance between front wheel and anti-tipper. Swing clamp up around bottom of tube. Install 2 1/4" Carriage bolt from the top and guide through hole in bottom of clamp. Install and **FIRMLY TIGHTEN** 1/4" lock nut.

Repeat for opposite side.

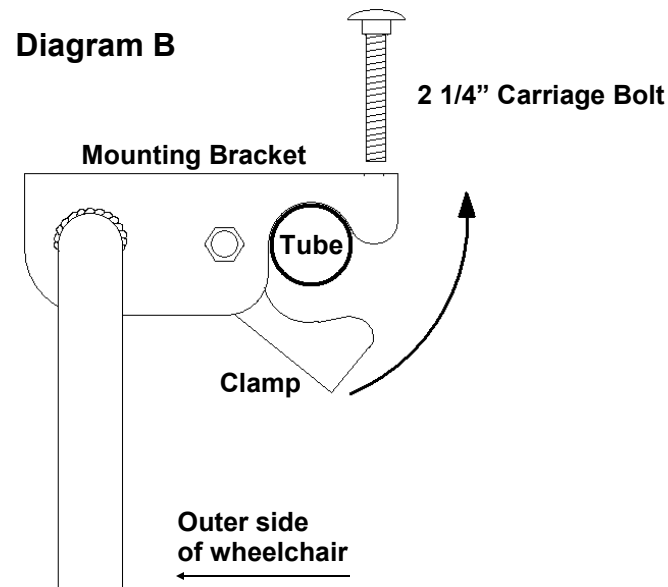

Periodically check installation for proper alignment and tightness.

1 Year Warranty
210 Innovations, LLC will repair or replace this product due to failure from manufacturing defects for a period of one year from purchase date.