

***Safe•t mate***<sup>®</sup> ***SM2***  
***Advanced Wheelchair Anti-Rollback Device***

## INSTALLATION INSTRUCTIONS

### MODELS

<b>SM2</b>	16"-20" wide chairs	<b>SM2W</b>	22"-24" wide chairs
<b>SM2A</b>	16"-20" w Optional Alarm	<b>SM2WA</b>	22"-24" w Optional Alarm

### **7 EASY STEPS USERS GUIDE INCLUDED**

*Before you begin!*

#### Tools Required

<b>3/8" open end wrench or socket</b>	<b>7/16" open end wrench or socket</b>
<b>1/4" open end or small adjustable wrench</b>	<b>Scissors</b>

The Safe•t mate in not designed for use with a solid drop seat or solid seat insert.

If the tires on the wheelchair are hard or brittle due to age, it may degrade the performance of this device.  
In this case we recommend replacing the tires.

This device is not a replacement for the factory installed brakes. The Safe•t mate wheelchair Anti-rollback Device is a back-up system which may reduce injuries when factory brakes are not used.  
Not a replacement for proper supervision. Supervise fall risk patients closely.

**U.S. PATENTS 6,092,824 6,279,963 6,371,503**

Manufactured by 210 Innovations, LLC  
34 Taugwonk Spur Stonington, CT 06378  
800-210-2298

[www.safetmate.com](http://www.safetmate.com)

# STAFF TRAINING TIPS

The Safe•t mate wheelchair Anti-rollback Device is designed to prevent a wheelchair from rolling back and away from the user as he/she attempts to sit down in or stand up from the chair. The chair will still move forward when the unit is engaged.

To facilitate moving the unoccupied chair in reverse, pull up on the temporary override lever to release the brake arms from the tires. **Do not attempt to rig the override feature to permanently disengage the device as this may cause a patient fall and serious injury.** If override lever has been removed, reach down and press on wheelchair seat to release brake arms.

Heavy seat cushions may prevent the seat lever from fully lifting the sling seat, in which case the seat cushion kit (included) may need to be installed. Whenever a new cushion is put into use, check for proper operation.

A wheelchair with the Safe•t mate Anti-rollback Device installed may be folded (for storage or transport) by removing the 2 quick-release pins that hold the center lever assembly in place. Be sure to retain the pins for reinstalling the lever assembly.

If the optional integrated alarm is in use, it should be removed prior to wheelchair washing. This is accomplished by loosening the mounting thumb screw (by hand) and removing the wire **at the alarm box. Do not attempt to unscrew the switch side of the wire from the anti-rollback device.** Once reinstalled, the alarm needs no further adjustment. However, it should be checked for proper operation.

The Anti-rollback Device should be inspected periodically to ensure that all the mounting hardware is securely tightened and that the brake arms are in proper adjustment. If the optional alarm is in use, it is preferable to have the battery changed on a frequent schedule. At a minimum, replace the 9 volt alkaline battery when horn volume begins to decrease.

## Troubleshooting guide

Condition	Possible Cause	Check/Remedy
Brake arms do not lift off tires with seat occupied.	Steps 4-7 not performed with chair occupied. Mounting brackets at improper frame location.	Review installation instructions.
Only one brake arm grabs tire when patient rises from chair.	Mounting brackets at different heights on frame. Faulty adjustment procedure.	Realign mounting brackets. Repeat steps 6,7
Brake arms rotate out of position or loosen.	Loose set screws or left and right brake arms swapped.	Ensure machined flat surfaces face up, readjust and <b>FIRMLY</b> tighten set screws.
Quick release pins difficult to remove.	Quick release pins intended to be tight to prevent tampering or accidental removal.	When removing, gently rotate lever assembly to relieve tension on pins.
<b>Optional Alarm</b>		
Horn volume is low or does not sound	Low / dead battery / faulty switch wire	Replace 9 volt battery. Remove switch wire from mounting bracket. With wire installed in alarm depress red switch. If alarm sounds switch is good. Remove wire from alarm and jump paper clip from inside contact of jack to outside contact. If alarm sounds, alarm is good.
Horn sounds intermittently	Cam may be at make/break point of switch.	Perform cam adjustment procedure.

## Warranty

The SM2, SM2A, SM2W and SM2WA are warranted to be free from defects in material and workmanship under normal operating conditions for a period of **one year**. 210 Innovations sole obligation under this warranty is limited to repair or replacement of defective parts including labor. This warranty does not cover failure due to abuse, misuse, alteration, improper assembly or installation. Please contact us at **800.210.2298**

# SAFE•T MATE SM2 PARTS BREAKDOWN

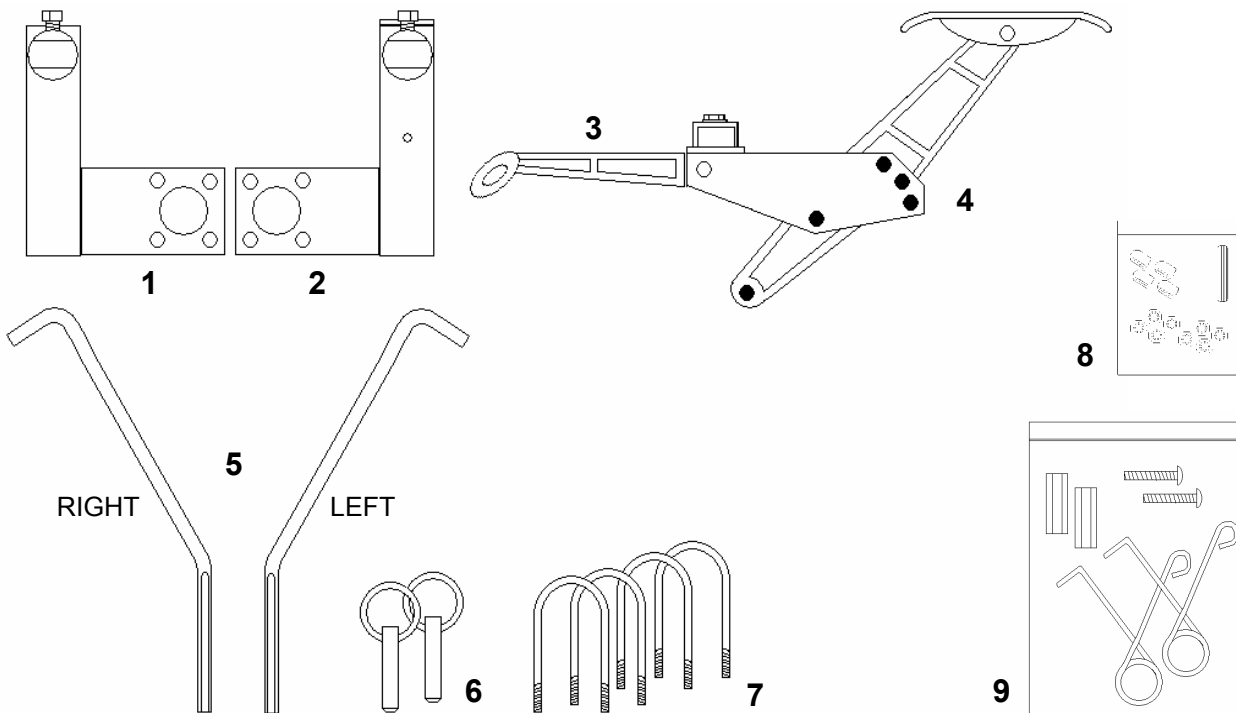

REF.	PART NO.	DESCRIPTION
1	SM2BRKTL	Left mounting bracket assembly complete
2	SM2BRKTR	Right mounting bracket assembly complete
3	SM2TOL	Temporary override lever
4	SM2LEVASSEMB	Lever assembly complete (includes SM2TOL) + 2 width adjusting bars
5	SM2ARMS	Set Left / right brake arms
6	QRPINS	Set 2 Quick release pins
7	SM2UBOLTS	Set 4 U-Bolts
8	SM2HWARE	8 Nuts / 4 End Caps / 1 Spacing Dowel
9	SM2SCK	Seat Cushion Kit

## OVERRIDE LEVER FUNCTION AND USE



### CAUTION

**Rigging the override lever to permanently disable the anti-rollback function may result in a resident fall and injury.**

The override lever is a removable caregiver feature that facilitates moving the unoccupied chair backwards. It will only release the anti-rollback device when manually lifted.

In an environment where patients are inclined to tamper with other patient equipment, it may be desirable to remove the override lever. Removal will not interfere with the function of the anti-rollback device.

### 3. INSTALL SEAT LEVER

Loosen the width adjusting bolts just enough to slide the width adjusting bars.

Install the seat lever as shown with the Quick-release pins provided. Do not tighten bolts at this time.



**STEPS 4-7 REQUIRE WHEELCHAIR SEAT TO BE OCCUPIED**

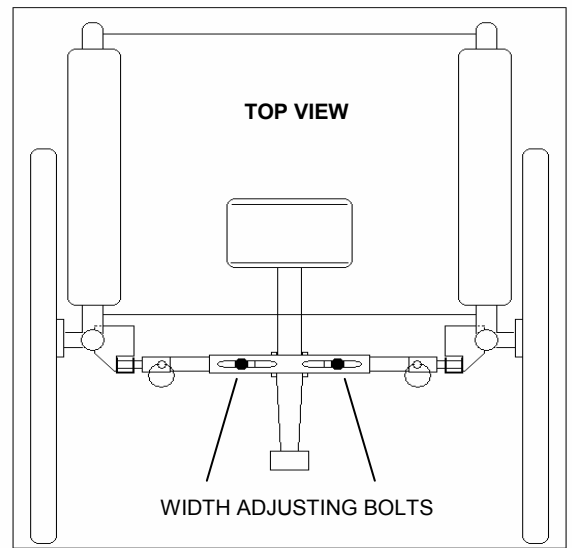

### 4. INSTALL BRAKE ARMS

While holding seat lever, **cut plastic ties** and let seat pad rotate up until it contacts seat bottom.

There are left and right brake arms. With the flat surface facing up, install the brake arms through the pivoting collars as shown.

If necessary, rotate **left** mounting bracket slightly on the chair frame to align the curved portion of the brake arm for maximum contact with tire as shown.

Tighten nuts on **left** mounting bracket U-bolts. Note. Be careful not to over tighten nuts as this may strip the threads.

Repeat step 4 for **right** side brake arm and mounting bracket.

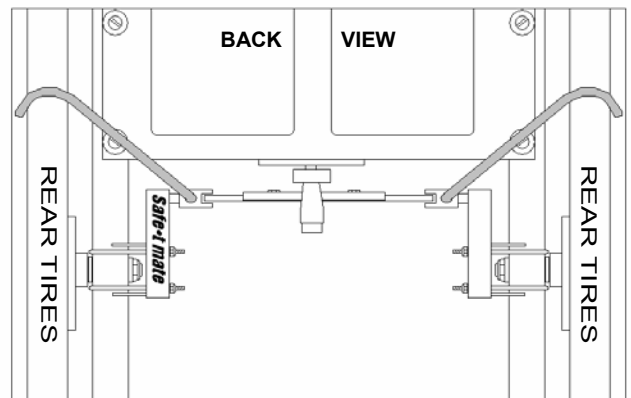

### 5. Center seat lever assembly and securely tighten width adjusting bolts.

### 6. ADJUST BRAKE ARMS

For proper spacing, slide the wooden spacing dowel (provided) between the **left** tire and brake arm. While pressing the arm against the dowel to hold it snugly, **FIRMLY** tighten the set screw.

Remove dowel and repeat procedure for **right** side. Install protective end caps (provided).

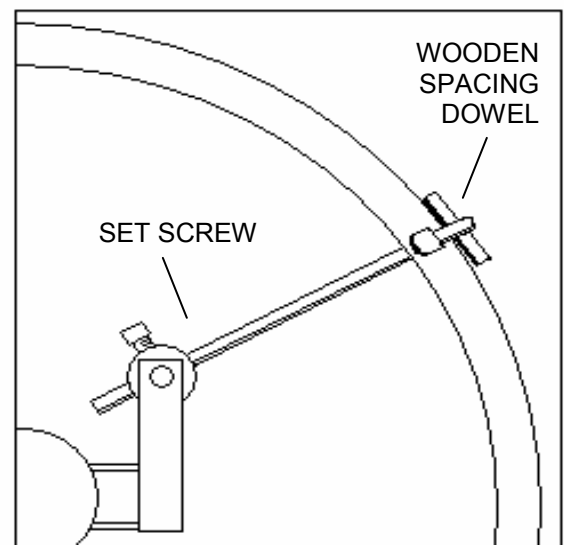

### 7. CHECK FOR PROPER OPERATION

As the occupant rises from the chair, the left and right brake arms should rotate down to grab the tires at the same time engaging the braking action. If one arm grabs less firmly (or not at all), repeat step 6 until continuity is achieved.

### 8. EVALUATE NEED FOR SUPPLIMENTAL SEAT CUSHION KIT (INCLUDED)

Some seat cushions are too heavy to allow the seat lever to fully rotate up as the patient rises and thereby not allowing the brake arms to fully engage the tires. If a seat cushion is to be used, install cushion and check for proper operation. If you determine that the supplemental kit is needed, refer to the installation instructions included with the kit.

Verify that you received all of the parts shown on page 4



**DO NOT REMOVE PLASTIC CABLE TIES FROM MOUNTING BRACKETS UNTIL INSTRUCTED**

## 1. INSTALL MOUNTING BRACKETS

The left mounting bracket is identified by the blue Safe•t mate label.

Standing behind the chair, mount the left and right brackets as shown, using the U-bolts provided \*\*. Note the upper U-bolt is **above** the axle and the lower U-bolt **below** the axle. **Snug** but do not completely tighten nuts at this time.

**\*\* When installing on adjustable height chair, brackets must be installed at axle in use.**

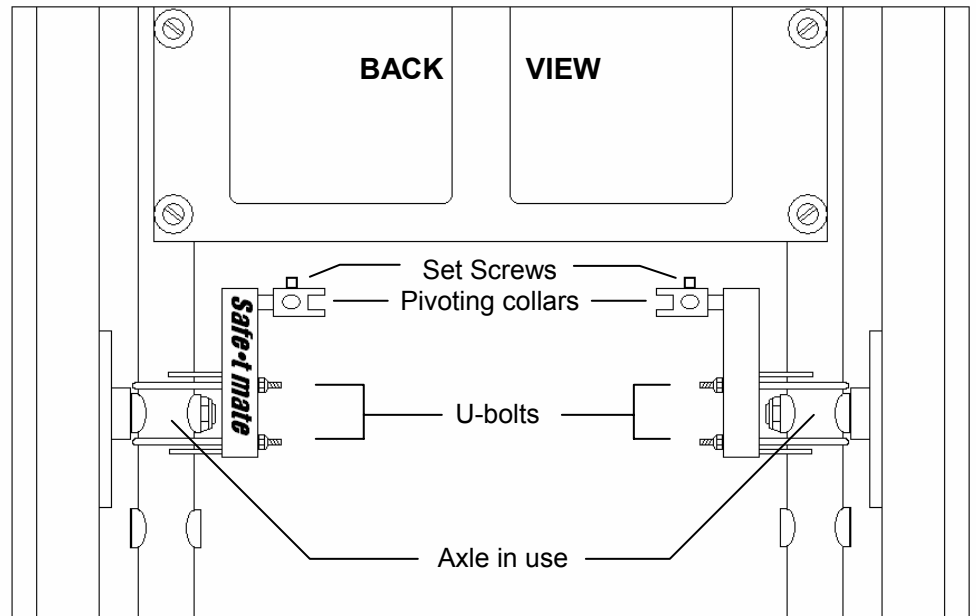

## 2. CONFIGURE SEAT LEVER

The lever has a total of 6 possible seat lever positions.

There are 2 seat depth adjustments (A,B) The seat depth adjustment is pre-assembled in Position A.

There are 3 lever height adjustments (1,2,3)

### Select Depth Adjustment

#### Position A

floating seat pad is at back third of seat. This position is suitable for most patients.

#### Position B

Seat pad is 2" further forward. If patients slouch in seat, this set-up will better depress seat lever to lift brake arms off tires. If position B is selected, remove 1/4" bolt and nut, move lever forward and replace bolt and nut. Do not tighten at this time.

### Select Height Adjustment

**1** for standard height chairs

**2** for hemi height chairs

**3** for super low hemi chairs

Determine proper height adjustment and install 1/4" bolt and nut.

**Tighten both seat lever bolts and nuts.**

